

D4 DOORS CAVITY SYSTEM

PRODUCT GUIDE

Architectural Sliding Door
Solutions Engineered for
performance. Designed for
modern spaces.

Where soft-close &
open is standard.





DESIGNED FOR DOORS

Australia's trusted supplier for premium cavity sliders. Delivering exceptional performance and style for residential and commercial applications.



It is not about us, it's about you. D4 doors are all about designing a system that you asked for.

At D4 Doors, we've listened to feedback from all levels—retailers, builders, carpenters, and homeowners alike. We've incorporated their diverse needs and expertise directly into our design, ensuring our products meet the highest standards of quality, functionality, and usability.

While our high-quality cavity unit sets have earned widespread acclaim, we remain committed to ongoing refinement and enhancement of both design and service. This dedication ensures we stay ahead of our customers' evolving needs, delivering exceptional solutions that exceed expectations.

WHY US

We take pride in our meticulous attention to detail. We are committed to using only the finest quality materials.

04 /

28



VERSATILE

Easily change between Flush-Jamb & Flush-Pull, no need to stock both styles.



THOUGHTFUL

Self-balancing rollers to auto-adjust for bowed doors.



ROBUST

Powder-coated, heavy duty aluminium tracks.



EASY INSTALLATION

One motion plate for fast installation.



PREMIUM

Soft close & open as standard, aluminium frame, touch open and more...

Our cavity sliders have undergone a series of rigorous tests to push their limits and ensure exceptional performance. The results are a testament to our commitment to quality. Our cavity sliders can confidently support heavy doors, ensuring secure and reliable operation. Its self-balancing rollers adjust to compensate for warping, settling, or other door movements.

D4 Doors provides high-quality cavity unit sets tailored for homeowners and builders alike, ensuring premium quality, effortless installation, and user-friendly operation.

D4 Doors Cavity sliders are sliding doors that disappear into a recessed cavity within a wall when opened. They are an elegant and functional alternative to traditional hinged doors. Here are several reasons to use cavity sliders:

Unlike traditional swinging doors, cavity sliders don't require clearance for the door to swing open, making them ideal for small rooms, tight spaces, or areas with limited floor space.

SPACE-SAVING DESIGN

Improves Room Layout Options: Furniture can be placed closer to the door opening since no swing path is needed.

Creates more possibility with the constrained floor space.

AESTHETIC APPEAL

Seamless Integration: When open, D4 Doors cavity sliders can be concealed within the wall, creating a clean and uncluttered appearance.

Modern Look: They add a sleek, contemporary touch to interiors and can complement minimalist design

ENHANCED FUNCTIONALITY

Versatility: They work well in various settings, including bathrooms, bedrooms, closets, pantries, offices and other residential and commercial settings.

Customizable Options: D4 Doors Cavity sliders are available in multiple designs, materials, and finishes to suit different décor themes.

IMPROVED ACCESSIBILITY

Ease of Use: D4 Doors Cavity Sliding doors are easier to open for people with mobility challenges, as they don't require pulling or pushing.

Barrier-Free Entry: They can be designed to meet Australian Standards, making spaces more inclusive.

OPTIMIZED FLOW BETWEEN SPACES

Open Plan Flexibility: They can act as a transitional feature between open and closed spaces, enabling users to partition areas when needed or create a flow between rooms.

Privacy Control: Ideal for rooms where privacy is occasionally needed, such as en-suite bathrooms or study spaces.

INCREASED PROPERTY VALUE

Appealing to Buyers: Modern, space-efficient designs like cavity sliders are often attractive to prospective homebuyers, potentially increasing the market value of a property.

WHY CAVITY UNITS?

SOLUTIONS FOR AWKWARD SPACES

Tight Corners: Perfect for spaces where hinged doors would collide with furniture or other architectural features.

Narrow Corridors: Useful in hallways or areas where traditional doors might obstruct movement.

ENERGY EFFICIENCY

Zone Control: Helps maintain different temperature zones in a home or office by closing off spaces when needed, leading to better heating or cooling efficiency.

DURABILITY AND LOW MAINTENANCE

Long-Lasting Mechanisms: High-quality cavity sliders with robust aluminium tracks and rollers are durable and require minimal maintenance.

Clean Lines: With fewer exposed components, they collect less dust and dirt compared to hinged doors.

05 /

28



COMPLETE SERIES

DESIGNED FOR VOLUMN BUILDER | PROJECT HOMES,
FOR MAXIMUM INSTALLATION SPEED AND RELIABILITY.

Quality built cavity system with aluminium tracks and soft-close. Wholesale through a large number of retailers in NSW and VIC.

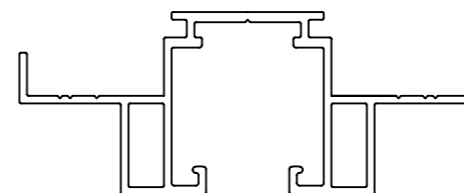

Our Complete Series design reflects a deep understanding of the market's needs. From the start, D4 Doors Complete cavities have received consistently positive feedback. We gathered insights from all levels of the industry, incorporating them into an innovative, cost-effective solution for the Australian building sector. Not only is it highly adaptable for carpenters, but it also enhances both installation and user experience.

The Complete Dual-Mode Series cavity is designed with a default 'Flush-Pull' setup, easily convertible to a 'Flush-Jamb' configuration in under 60 seconds. Paired with the D4 Doors Touch Open Release, it's ideal for adding both style and functionality to any design.

PRODUCT INFORMATION

D4 Doors Complete cavity sliders feature durable aluminum tracks and jump-proof, self-balancing roller wheels that adapt to door deformation, help lasting performance and peace of mind. With a soft-close and open mechanism, these sliders provide smooth, quiet gliding for a disturbance-free experience in the both residential and commercial projects.

Smart Jamb Spacers are included to reduce impacts to the units during construction.

- Max. Door Height: 2340mm
- Max. Door Width: 1200mm
- Max. Soft-close Capacity: 65kgs
- Max. Door Thickness: 40mm
- Type of Doors: Timber
- Plasterboard Thickness: 10mm

CUSTOM ORDER

We offer custom sized up to 2340x1200mm Complete range cavity sliders in commercial quantities.

TRIM OPTIONS

- Flush-Jamb, flush-Pull convertible
- Architrave on 10mm plasterboards
- P50 Shadow-line
- P25 Stopping angle

MATERIALS

- Powder-coated aluminium track.
- LVL nogging & post
- Triple coated finger jointed primed pine split jambs and pelmets.
- Galv. Steel split jambs.

INCLUSION

- Pine pelmets;
- Self-balancing roller wheels;
- One motion quick release plates;
- Split-jambs to suite 10mm Plasterboard
- Soft-close both directions to suit doors up to 65kgs;
- Smart Jamb Spacers;
- Standard floor guide options;
- Rebated Primed Pine Closing Jamb. (Optional)



COMPLETE PLUS SERIES

TOWNHOUSES | MID-RANGE HOMES



D4 Doors Complete Plus Dual-mode Series range cavity units are designed for standard size doors on 90mm stud size with some sweet touches such as aluminium frames and cavity brush-seal. Includes soft-close & open mechanism and self-balancing roller wheels.

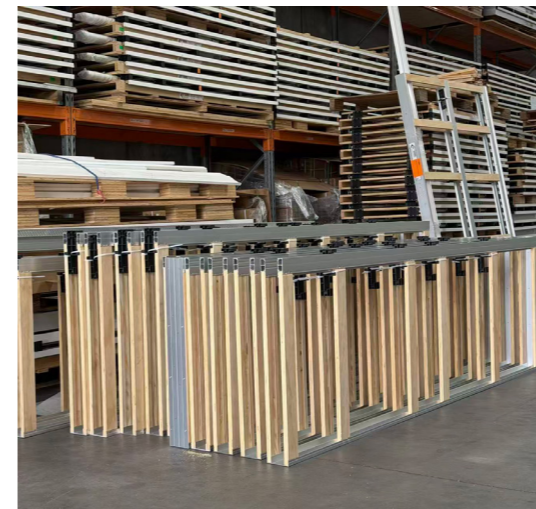

PRODUCT INFORMATION

Building on the Complete range, the D4 Doors Complete Plus cavity slider is engineered for higher performance and smoother operation. Its advanced one-motion cast alloy quick-release bracket delivers quieter running and handles both lightweight and heavy doors with ease—without compromise.

Premium inclusions like brush seals and a concealed bottom guide come standard, improving finish and functionality—without inflating the price.

- Max. Door Height: 2340mm
- Max. Door Width: 920mm (Std) / 1200mm (X-Wide Centre Mullion)
- Max. Soft-close capacity: 90kgs,
- Max. Door Thickness: 40mm
- Type of Doors: Timber
- Plasterboard Thickness: 10mm (Std) / 13mm (Opt)

TRIM OPTIONS

- Flush-Jamb, flush-Pull convertible
- Architrave
- P50 Shadow-line
- P25 Stopping angle

When designing the Complete Series units, we asked ourselves, why not offer more 'premium' features at an exceptionally affordable prices?

In addition to the standard features of the Complete Range cavity sliders, we've included extras like cavity brushes, aluminium split jambs, posts, and bottom plates with concealed guides.

The X-Wide Factor features robust aluminium centre mullions that reinforce the entire structure, making them ideal for doors wider than 920mm. This added rigidity gives designers, builders, and homeowners greater freedom to choose diverse wall finishes—think elegant wall tiles, rich marble, statement feature walls, and beyond...

INCLUSION

- Timber pelmets;
- Self-balancing roller wheels;
- Robust spring actioned quick-release plates;
- Split-jambs to suite 10mm Plasterboard. Optioned up-to 13mm;
- Soft-close both directions to suit doors up to 90kgs;
- Smart Jamb Spacers;
- Splayed Guides, 'T'-Shape Nylon Guides;
- Concealed floor guide;
- Rebated Closing Jamb..

MATERIALS

- Double wall design powder-coated aluminium track.
- LVL nogs & aluminium post and robust aluminium centre mullions.
- White primed F/J pine split reveals backed by triple wall aluminium jambs with cavity brush.

09 /

28



ATLAS SERIES

ARCHITECTURAL HOMES

D4 Doors ATLAS Series cavity units are the ultimate choice for architectural designed projects. Thorough designed frame designed for 90mm stud walls with all the premium inclusions, minus the need for any pelmets, simply the best Zero Clearance cavity slider.

Fully customizable cavity system allows a wide range of options and features.



D4 Doors ATLAS Series is the best option for your zero-clearance requirements.

The D4 Doors ATLAS Cavity Range sets a new benchmark in sliding door systems, delivering a true zero-clearance finish with soft-close and soft-open functionality as standard.

Its smart closing jamb complements any design style, while the innovative quick-release system achieves an ultra-sleek minimum top clearance of just 3.5mm.

PRODUCT INFORMATION

D4 Doors ATLAS Cavity range allows users to have a true zero-clearance sliding door that also comes with soft close mechanism. Minimum top clearance achieved is 3.8mm thanks to the smart designed quick-release.

This is a great option for residential and commercial uses in architectural designs.

- Max. Door Height: 3000mm
- Max. Door Width: 2000mm
- Stud thickness: 90 or 100mm
- Max. Soft-close Capacity: 120kgs.
- Max. Door Thickness: 50mm
- Type of Doors: Timber or frameless glass.
- Plasterboard Thickness: Customized

CUSTOM ORDER

MAX 3000H X 2000W, on 90mm or 100mm Stud

Please contact us to find out how our products can be tailored to your projects.

TRIM OPTIONS

- Architrave
- P50 Shadow-line
- P25 Stopping angle
- Ezy Jamb style square-set
- Custom trims to suit any wall finishes

MATERIALS

- Double wall design powder-coated aluminium track.
- ATLAS-Lite: LVL nogs & 2 cell-aluminium post
- ATLAS: F/J Primed Pine nogs & 4 cell-aluminium post
- Square-Set: Intergrated aluminium square set trim system allows fast fixing.

INCLUSION

- Self-balancing roller wheels.
- Robust quick-release plates to achieve 3.5mm minimum top clearance;
- Soft-close both directions with touch open to suit doors up to 100kgs.
- Smart Jamb Spacers.
- Splayed Guides, 'T'-Shape Nylon Guides, Concealed 'T'-Guide.
- Rebated Closing Jamb.



ATLAS SERIES

FULL CUSTOMIZATION TO SUIT YOUR DESIGN

Our cavity sliders have undergone a series of rigorous tests to push their limits and ensure exceptional performance. The results are a testament to our commitment to quality. Our cavity sliders can confidently support heavy doors, ensuring secure and reliable operation. Its self-balancing rollers adjust to compensate for warping, settling, or other door movements.

D4 Doors provides high-quality cavity unit sets tailored for homeowners and builders alike, ensuring premium quality, effortless installation, and user-friendly operation.

012 / 28



SPLIT JAMB OPTIONS

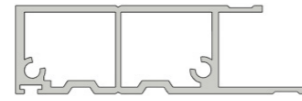

ATLAS-LITE: TWO-CHAMBER ALUMINIUM

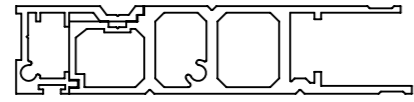

ATLAS: FOUR-CHAMBER ALUMINIUM



ATLAS-X: FOUR-CHAMBER ALUMINIUM WITH STEEL INSERTS

TRACK OPTIONS

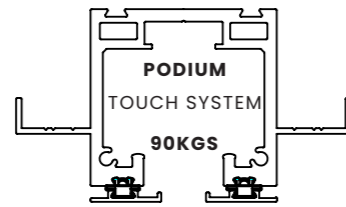
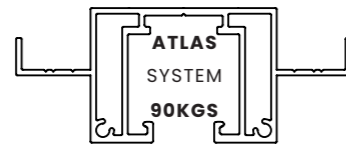

CLOSING JAMB OPTIONS

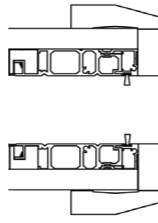

ARCHITRAVES

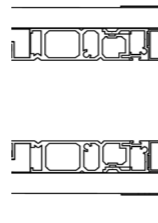

REBATED SQUARE-SET

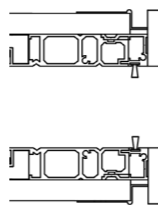

P50 SHADOWLINE

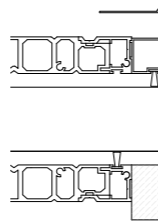

MIX & MATCH

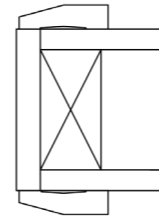

FLAT

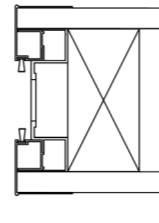

REBATED

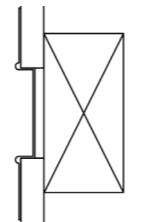

CORRIDOR

TYPICAL ELEVATION

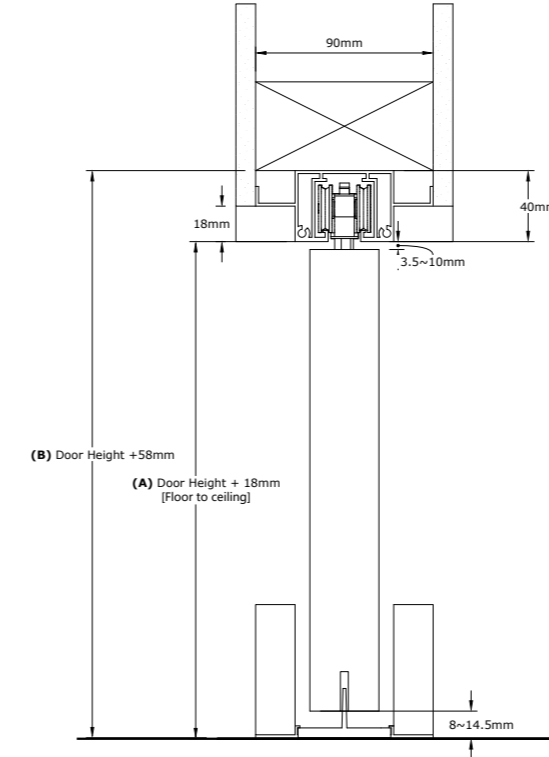

OPERATING OPTIONS

- Soft-close + Soft-open
- Soft-close + D4 Push Release (No open hold)
- Soft-close + JEXIS Push Release (Reduced bounce)
- PODIUM Touch System: Soft-close + Soft-open + Touch Release

FINISH OPTIONS

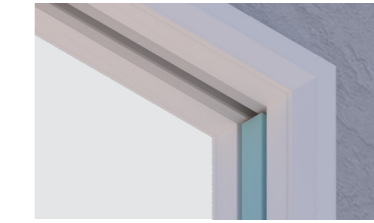

BULKHEAD ARCHITRAVES



FLOOR-TO-CEILING ARCHITRAVES

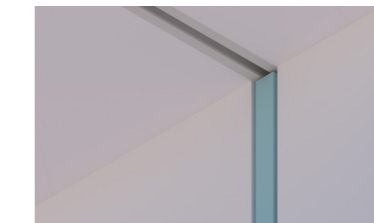

CORRIDOR

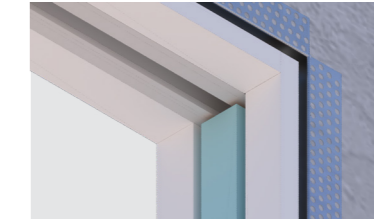

BULKHEAD SHADOWLINE



FLOOR-TO-CEILING SHADOWLINE

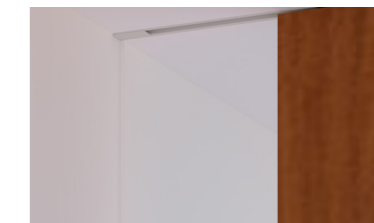

CORRIDOR

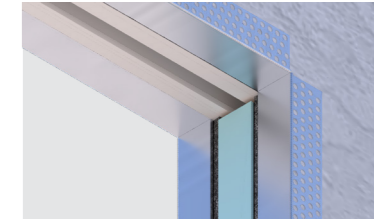

BULKHEAD SQUARE-SET

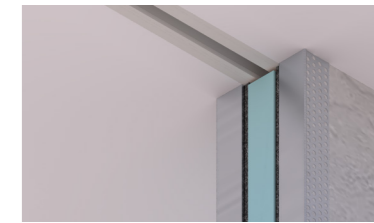

FLOOR-TO-CEILING SQUARE-SET

ATLAS-X SERIES

HIGH-END RESIDENCES | COMMERCIAL

Robust, light weight, rust & moist resistant, full customization, ultra heavy capacity...

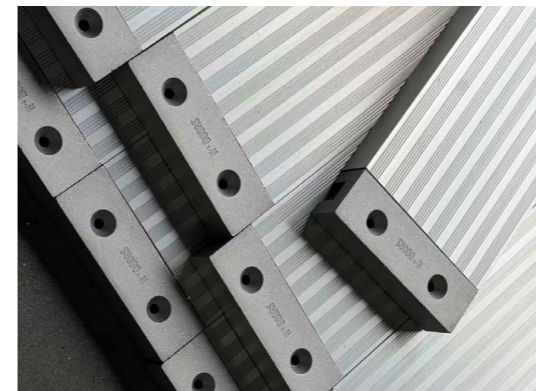

TRACK OPTIONS

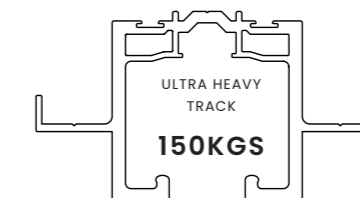
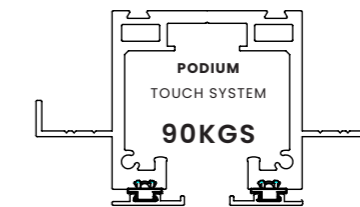
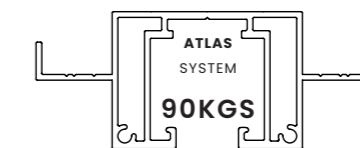

- Max. Door Height: 3500mm
- Max. Door Width: 2500mm
- Max. Door Thickness: 40mm on 90mm Stud, 50mm on 100mm stud.
- Max. Soft-close Capacity: 150kgs
- Type of Doors: Timber or frameless glass.

MATERIALS

- Double wall design powder-coated aluminium track;
- Full aluminium body.

CORE SYSTEM ADVANTAGES

TRUE HEAVY-DUTY PERFORMANCE

Designed To Support Large-Format And High-Mass Doors Without Deflection, Maintaining Smooth Operation Over Time In Demanding Environments.

OMNI ALUMINIUM BODY (FULL-SYSTEM STRENGTH)

A fully aluminium framework delivers structural rigidity without excess weight, while providing long-term resistance to corrosion, movement, and job site wear. Suitable for any construction application.

PRECISION INSTALLATION

Height-adjustable nogging system allows on-site flexibility and accurate alignment—critical for achieving tight tolerances and clean architectural finishes.

BUILT FOR HIGH-TRAFFIC USE

Engineered for repeated, daily operation in both residential and commercial settings without performance drop-off.

TRIM OPTIONS

- Architrave
- P50 Shadow-line
- P25 Stopping angle
- Ezy Jamb style square-set

INCLUSION

- Heavy duty roller wheels.
- Strong base plate easy for installation.
- Split-jamb to suite up to 13mm plasterboard.
- Soft-close mechanism to suit doors up to 120kgs.
- Smart Jamb Spacers.
- Rebated Closing Jamb.
- Bottom Aluminium Roller Guide.

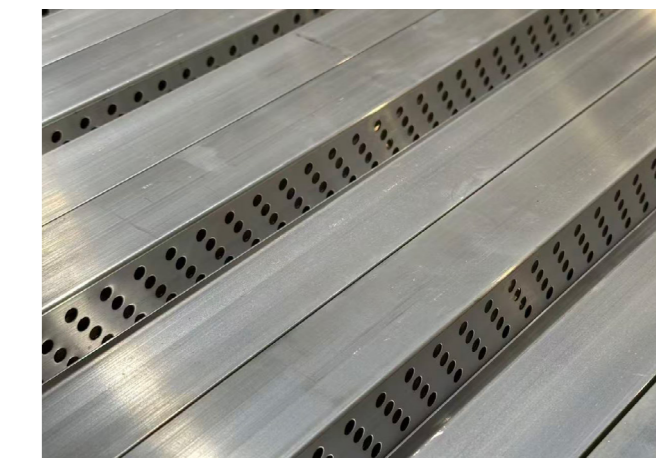

A.L.P.S. SERIES

COMMERCIAL & HOSPITALITY



D4 Doors A.L.P.S sliding system is a best automated sliding solution on the market. It offers small bulkhead, silent operation and advanced access control options.

D4 Doors A.L.P.S. stands for Automated Levitation Precision Sliding system.

NO MAINTENANCE CUT-OUT on the wall, Australia's 1st automatic cavity sliding system. All servicable components can be removed from track cut-out, no more maintenance cut-out on the wall.

PRODUCT INSTRUCTION

D4 Doors A.L.P.S., also known as the Automatic Levitation Precision Sliding System is the most advanced auto sliding system. It eliminates rubber belt/chain operations and utilized state-of-the-art magnetic levitation technology that allows reduced friction with adjustable speed of sliding, ideal for all commercial settings.

KEY FEATURES OF A.L.P.S SYSTEM

AI FUNCTIONALITY

- **Sensors:** Use highly sensitive pressure or proximity sensors to detect obstacles in real time.
- **AI Algorithm:** Train the module to distinguish between regular operation and obstruction scenarios.
- **Safety Mechanism:** Automatically halt or reverse movement when an obstacle is detected to prevent damage or injury.
- **Memory Retention:** Include non-volatile memory to store the last known position of the module.
- **Calibration Routine:** Upon power restoration, the system automatically adjusts to the stored position or recalibrates using reference points.
- **Manual Override:** Allows manual operation just like a normal sliding door when power is not available.
- **Adjustable sliding speed.**

BELT-FREE OPERATION

- Quiet Motors and minimum friction;
- Minimal wear and tear, pro-longed lift span;

- Low energy consumption, only 0.002 kw per hour when idle.
- Compact Design: Optimize the mechanical design to minimize space requirements for installation.

A.L.P.S. system can be used as track only in either top fix or face fix options and is also fully compatible with D4 Doors frames including the Complete Plus, ATLAS and ROBO series.

- Max. Door Height: 3500mm with ATLAS-X Frame
- Max. Door Width: 2500mm with ATLAS-X Frame 4000mm Track Only
- Max. Door weight: 80kgs (90mm Stud)
360kgs (100mm Stud)
500kgs (Track Only)
- Type of Doors: Timber, aluminium or glass.
- Operation Speed: 100-500mm per second
- Auto hold: 0-30 seconds

CUSTOM ORDER

Please contact us to find out how our products can be tailored to your projects.

ACCESS CONTROLS

- Push button
- Remote Control
- Contactless (Wave) sensor
- Infrad Proximity sensor
- Security Card | Finger print Access
- Force Sensor
- Manual Override
- Control via 3rd party system

INCLUSION

- Robust quick-release plates to achieve 3.8mm minimum top clearance;
- Electric levitation permanent magnetic with motor to suit 240V power supply.
- Smart Jamb Spacers.
- Splayed Guides, 'T'-Shape Nylon Guides, Concealed 'T'-Guide.
- Rebated Closing Jamb.

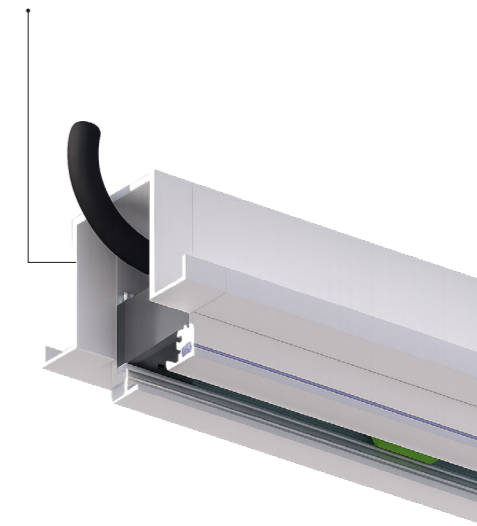
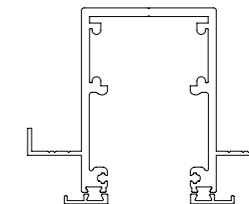

017 /

28

CHOOSE THE RIGHT SYSTEM

Product Selection Guide

	Frame System				Track System	
	Complete	Complete Plus	Atlas	Atlas-X	Podium	A.L.P.S.
Usage						
Volumn Builder/Project Home						
Custom Homes						
Architectural Homes						
Luxury Residences						
Commercial & Hospitality						

Strength & Capacity

Soft-close Capacity in cavity frame (Up to)	65kgs	65kgs	80kgs	★ 150kgs	100kgs	80kgs
Soft-close Capacity track-only (Up to)	-	-	-	-	100kgs	500kgs
Split Jamb						
Galvanized Metal		-	-	-		
Aluminium (2-Cell)	-		-	-		
Aluminium (4-Cell)	-					
Reinforced Aluminium				★		
Nogging Material						
LVL			(<2340mm)	-		
White Primed FJ Pine	-	-		-		
Height Adjustable Aluminium	-	-	-	★		

Spec & Finish

	Frame System				Track System	
	Complete	Complete Plus	Atlas	Atlas-X	Podium	A.L.P.S.
Maximum Frame Size (mm)	2340x1200	2340x1200	3000x2000	3500x2500		
Stud Thickness (mm)	90	90	90/100	90/100		
Trim Finish						
Architrave/Shadowline						
Intergrated Squareset (6/10/13/16/26mm)	-	-				
Custom Trims	-	-				
Bottom Guides						
Standard nylon guides						
Concealed T guide						
Concealed Roller guide with track						
Features						
Floor-to-ceiling	-	-				
Pelmets Required			-	-		
Zero-Clearance	-	-	★	★		
Operation						
Soft-close & Soft-open						
Soft-close & JEXIS Push Open						
Soft-close, soft-open & Touch release	-	-			★	
Magnetic Levitation (Automatic)	-	-	-			

BARN SERIES

Barn doors are a versatile and stylish addition to any space, offering both functional and aesthetic advantages.

020 / 28



1 SPACE-SAVING DESIGN

Barn doors slide along the wall instead of swinging open, making them ideal for small rooms or tight spaces.

Benefit: Maximizes usable floor space, perfect for closets, bathrooms, or rooms with limited square footage.

2 STYLISH AND VERSATILE AESTHETIC

Barn doors add a unique, rustic, or modern touch to any interior design, depending on the style and finish.

Benefit: Available in a variety of materials (wood, glass, metal) and designs to match any decor, from farmhouse to contemporary.

3 EASY TO INSTALL AND OPERATE

Barn doors are relatively simple to install compared to traditional doors, especially in spaces where door frames are not practical.

Benefit: Smooth sliding mechanism makes them easy to open and close, even for children or individuals with limited mobility.

4 FUNCTIONAL ROOM DIVIDERS

Barn doors can be used to separate spaces without the need for permanent walls, offering flexibility in room layout.

Benefit: Ideal for open-plan living areas, home offices, or multi-purpose rooms.

5 DURABLE AND LOW-MAINTENANCE

Made from sturdy materials and designed for frequent use, barn doors are built to last.

Benefit: Requires minimal maintenance and is resistant to wear and tear, making it a cost-effective long-term solution.

*** BONUS BENEFIT: CUSTOMIZABLE

Barn doors can be customized in size, color, and design to fit specific spaces and match personal preferences.

Benefit: Offers endless design possibilities to create a unique look for your home or office.



PRODUCT INFORMATION

- Max. Door Height: TBA
- Max. Door Width: 1500mm
- Max. Door weight: 80kgs



021 / 28

EXAMPLE USE CASES:

Bedrooms:	Adds a rustic or modern touch while saving space.
Bathrooms:	Provides privacy without taking up floor space.
Living Rooms:	Acts as a stylish room divider for open-plan spaces.
Closets:	Offers easy access and a decorative element.

PHANTOM SERIES

The secrete entry – concealed hardwares creates the impossibles.



PRODUCT INFORMATION

- Max. Door Height: TBA
- Max. Door Width: 1500mm
- Max. Door weight: 80kgs



PATENTED PRODUCT:

This product is protected by patents, ensuring its unique design, functionality, and innovation are legally recognized and safeguarded across multiple countries. This also highlights its exclusivity and superior engineering.

FULLY CONCEALED HARDWARE AND MECHANISM, ONLY 160MM OVERLAP ON THE OPENING WIDTH:

The hardware and mechanical components are entirely hidden from view, providing a sleek and minimalist appearance. The system requires only a 160mm overlap on the opening width, making it space-efficient and ideal for modern, compact designs.

DUAL SUSPENSION TO SELF-CALIBRATE FOR UNEVEN FLOOR FINISH:

The dual suspension system allows the door to automatically adjust and self-calibrate to compensate for uneven floor surfaces. This ensures smooth operation and eliminates the need for manual adjustments, even in environments with imperfect flooring.

2D ADJUSTMENT, ABLE TO ADJUST SPACING DISTANCE BETWEEN THE DOOR AND THE SUPPORTING WALL:

The product features two-dimensional (2D) adjustment capabilities, enabling precise alignment of the door. Users can easily adjust the spacing distance between the door and the supporting wall, ensuring a perfect fit and seamless integration with the surrounding structure.

QUICK-FIT SOFT-CLOSE & OPEN DEVICE:

The system includes a quick-fit mechanism for easy installation, along with a soft-close and open feature. This ensures the door closes and opens gently, reducing noise and wear while enhancing user convenience and safety.

FINE CRAFTED STAINLESS STEEL COMPONENT FOR LONGEVITY:

High-quality stainless steel components are meticulously crafted to ensure durability and resistance to corrosion. This guarantees long-lasting performance and maintains the product's aesthetic appeal over time.

AVAILABLE FOR TIMBER DOORS AND ALUMINIUM FRAMED GLASS DOORS:

The system is versatile and can be used with both timber doors and aluminium-framed glass doors. This makes it suitable for a wide range of applications, from traditional to contemporary designs, catering to diverse customer preferences.

AVAILABLE IN FLAT-PACK WITH DETAILED INSTRUCTION MANUAL FOR 1200 OR 1500MM TRACK:

The product is supplied in a flat-pack format, making it easy to transport and handle. It comes with a comprehensive instruction manual for straightforward assembly and is compatible with either 1200mm or 1500mm tracks, offering flexibility for different installation requirements.



SUSTAINABILITY

D4 Doors is proudly operates with a 100% FSC Chain-of-custody.

Our products are crafted with 100% FSC-certified materials, a testament to our unwavering commitment to sustainability and responsible sourcing. By choosing FSC-certified materials, we ensure that every product originates from responsibly managed forests that prioritize environmental, social, and economic balance. At D4 Doors, sustainability isn't just a goal—it's a core value woven into every aspect of our operations.

We are dedicated to minimizing our environmental impact while delivering products of exceptional quality and durability. By embracing eco-friendly practices and promoting renewable resources, we strive to protect natural ecosystems, support forest-dependent communities, and contribute to a greener future.

When you choose our products, you're not just investing in superior craftsmanship—you're supporting a mission to safeguard our planet for future generations. Together, we can build a more sustainable world, one product at a time.



As a leading wholesaler, we specialize in providing innovative, durable, and stylish cavity sliding doors designed to transform spaces with elegance and functionality.

OUR MISSION

At D4 Doors, our mission is to redefine interior spaces by offering premium cavity systems that maximize space, enhance aesthetics, and improve functionality. We are committed to delivering exceptional products that meet the diverse needs of homeowners, architects, contractors, and designers.

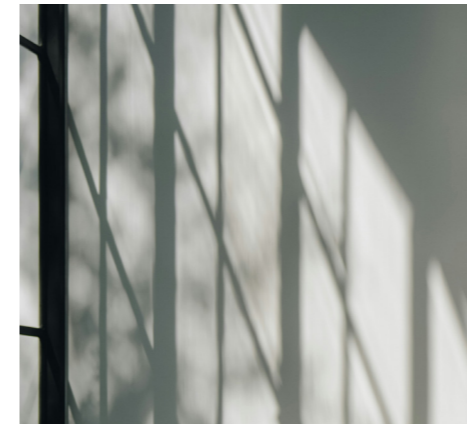

OUR VISION

We aim to be the preferred choice for pocket door solutions across residential and commercial markets. By blending style, innovation, and practicality, we aspire to set new standards in interior design.



EVERYTHING FOR DOORS

PARTNER WITH US

Whether you're a contractor looking for bulk orders, a designer seeking unique solutions, or a retailer needing a dependable supplier, D4 Doors is here to support your success. Together, let's create spaces that inspire.



TIMBER MOULDING

Chances are, you've come across our products without realizing they're ours. With over 18 years of expertise serving prominent wholesalers in Australia, we've honed our ability to deliver superior primed finish mouldings.

Our introduction of Maxtrim™ primed pine finger-jointed mouldings in 2022 has quickly earned extensive praise, and helped countless number of projects and homes across NSW.



SKIRTING & ARCHITRAVES

SIZE	PACK SIZE
42x11	357/5.4
67x11	224/5.4
90x11	176/5.4
116x11	132/5.4
138x11	128/5.4
18x18 & Quad	640/5.4
42x18	272/5.4
67x18	176/5.4
90x18	128/5.4
110x18	96/5.4
116x18	96/5.4
119x18	96/5.4
138x18	80/5.4
185x18	64/5.4

PROFILE

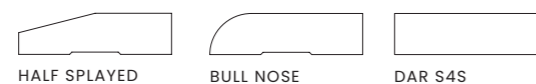

SINGLE REBATED DOOR JAMBS

“Single genuinely owned factory manufactured for consistent quality...”

SINGLE REBATED JAMB

SIZE	REBATE	PACK SIZE
90x30	38x12	72/5.2
110x30	38x12	60/5.2
116x30	38x12	60/5.2
119x30	38x12	60/5.2
125x30	38x12	50/5.2
138x30	38x12	50/5.2
165x310	38x12	45/5.2
185x30	38x12	45/5.2
235x30	38x12	40/5.2
285x30	38x12	38x12

WHY MAXTRIM?

- NEW ZEALAND Pine Cores
- 100% Knot-free clear grade
- Three coats
- Lab tested water-resistant reveal coating
- Custom profiles available
- The beset Value-for-Money moulding products in



Left: Other Reveal Right: Maxtrim Reveal

Aluminium foil tape to seal the cut surface is strongly recommended for added protection.

WATER-RESISTANT WINDOW REVEAL E4E

We know not all project runs on time and that made windows being left outside for weeks isn't hardly seen. We have engineered our coating and tested in the lab to reduce the extream Australian's weather effect being enforced to the timber reveals.

WATER-RESISTANT WINDOW REVEAL

SIZE	PACK SIZE
90x18	128/5.6
100x18	96/5.6
110x18	96/5.6
116x18	96/5.6
127x18	80/5.6
138x18	80/5.6
165x18	64/5.6
185x18	64/5.6

TESTED

3 X REPETITIONS

- / 16 HRS UNDERWATER /
- / 4 HRS IN FREEZER /
- / 4 HRS IN 80 DEG OVEN /



QOR BUILDING SYSTEMS

QOR — Quality of Refinement reflects the philosophy behind the our work. Every detail is engineered with precision, simplicity, and finish in mind. From clean square-set lines to refined tolerances and seamless integration with contemporary interiors, QOR represents a commitment to delivering not just functionality, but a superior level of craftsmanship and aesthetic performance.

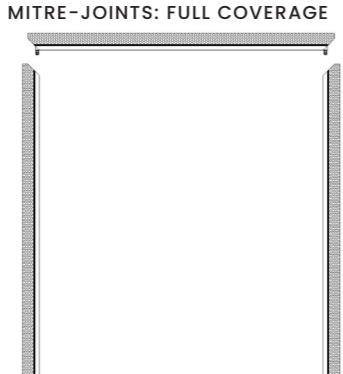
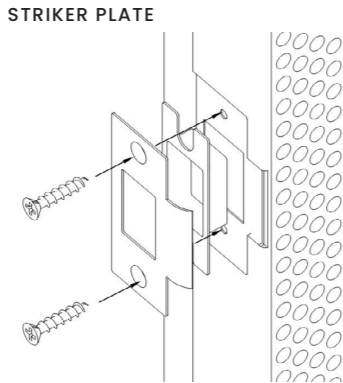
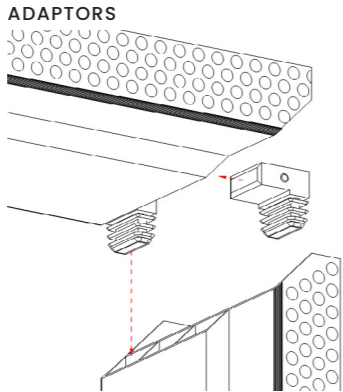

SUITABLE FOR 112 & 118 WALL THICKNESS

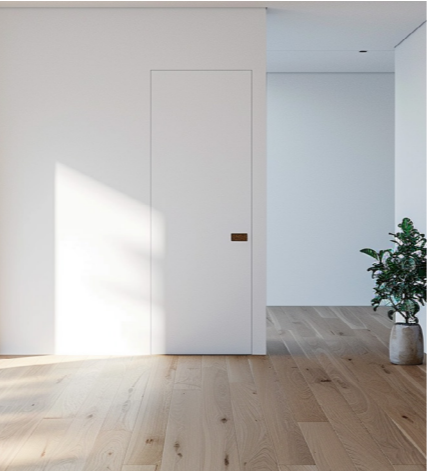
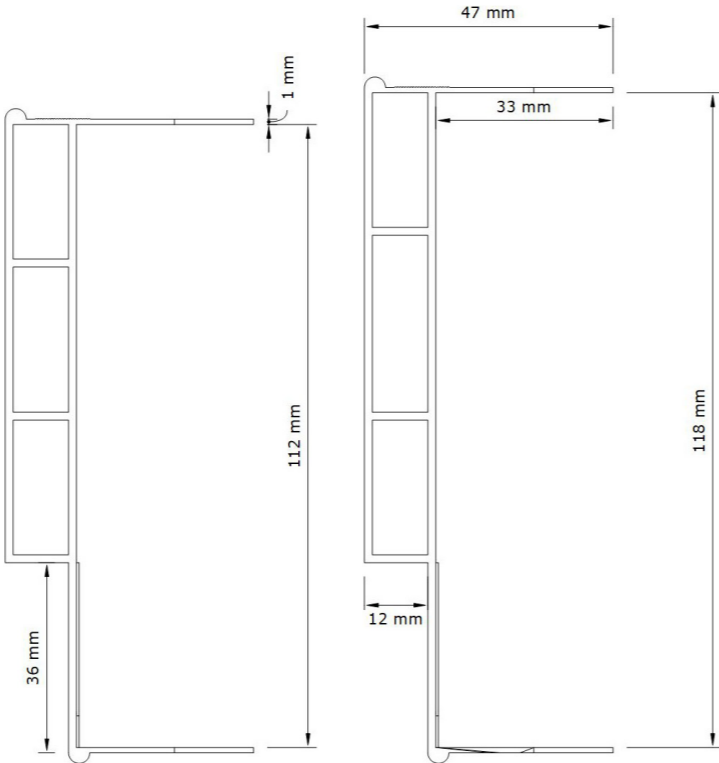

PRODUCT INFORMATION

The QOR SRJ (Single Rebated Square Set Door Jamb) is a premium aluminium door jamb system designed for modern architectural applications. Manufactured from high-quality extruded aluminium, it features a smart locking mechanism for secure and precise installation.

The QOR-SRJ is easy to work with, quick to install, and delivers a sleek, seamless square set finish—making it ideal for contemporary interiors.

- Max. Door Height: 3000mm
- Max. Door Width: 2400mm
- Door Thickness: 35/40mm
- Hinges Type: Flush, Lift-off and Concealed.
- Wall Thickness: 112mm, 118mm

STANDARD INCLUSION:

- 3 x Flush Hinges (in SS, Black, Gold, Gunmetal)
- 2 x Frame Joiners
- 1 x Striker plate & dust box

ACCESSORIE

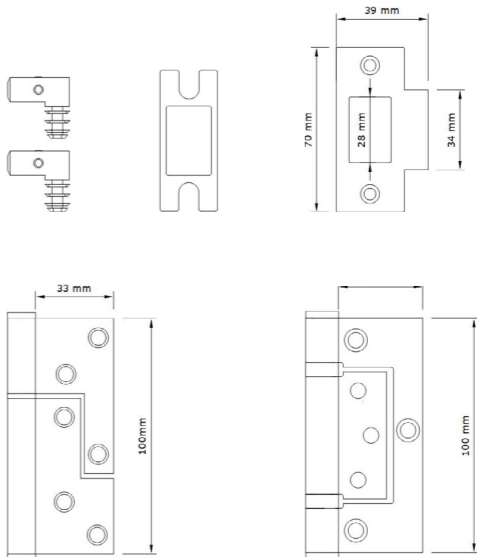



HARDWARES

We also wholesale designer Pull Handles, Mortice Locks, Dead Bolts, Cavity Locks, Door Stoppers, Standard Hinges & Concealed Hinges.

JNF developed an innovative magnetic lock with flush handle concept for sliding doors. The concept was based in the simplicity of operation, basic shapes, ergonomics and very easy installation. The activation and locking without noise was one of our main focus on the development, as this type of locks is mainly used for residential purpose the comfort is mandatory.

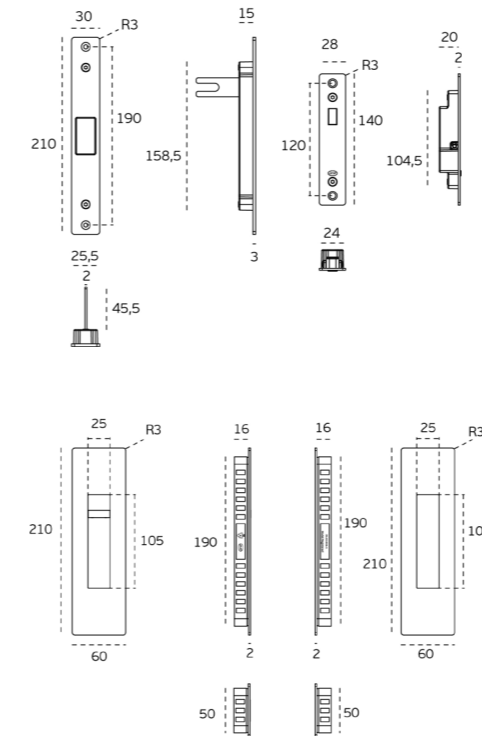
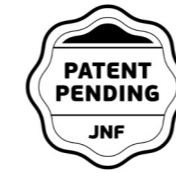

MORTISE LOCKS FOR SLIDING DOORS





SCAN TO ORDER



If your local building supply store doesn't carry our products yet, feel free to let us know.

We'll make it easier for you to find us.

